

REPLACEMENT

1. REPLACE COMPANION FLANGE DUST DEFLECTOR, IF NECESSARY

- (a) Using SST, a socket wrench and a press, remove the dust deflector.

SST 09950-00020

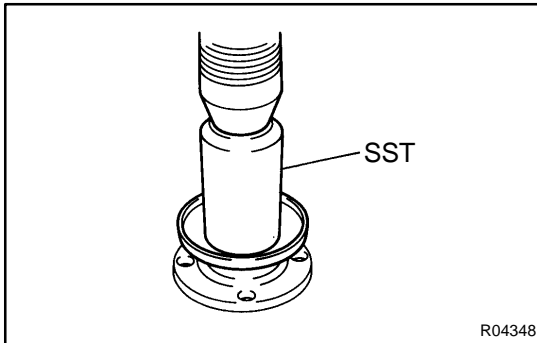

- (b) Using SST and a press, install a new dust deflector.

SST 09636-20010

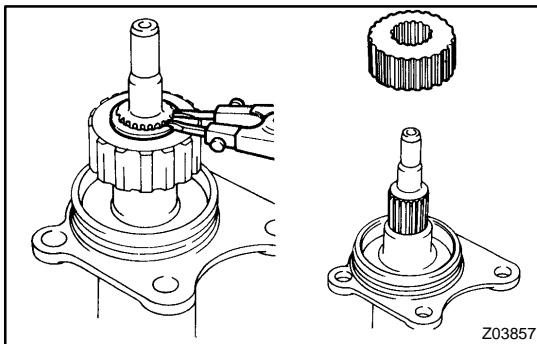

2. REPLACE INTERMEDIATE SHAFT NO. 2, IF NECESSARY

- (a) Remove the clutch hub.

- (1) Using a snap ring expander, remove the snap ring.
- (2) Remove the clutch hub from the intermediate shaft No. 2.

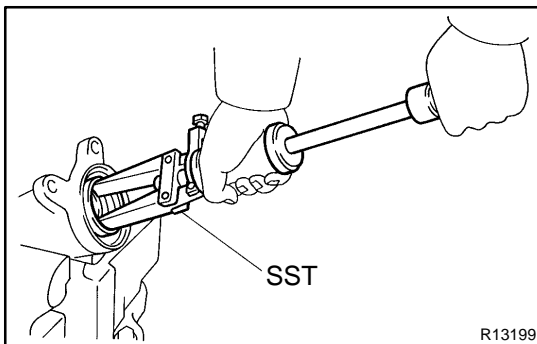

- (b) Remove the oil seal.

Using SST, remove the oil seal from the tube.

SST 09308-00010

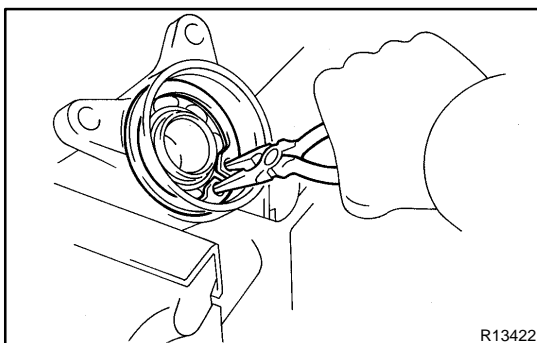

- (c) Remove the intermediate shaft No. 2 from the tube.

- (1) Using needle nose pliers, remove the snap ring.
- (2) Remove the shaft from the tube.

- (d) Remove the intermediate shaft No. 2 bearing.

- (1) Using a snap ring expander, remove the snap ring.

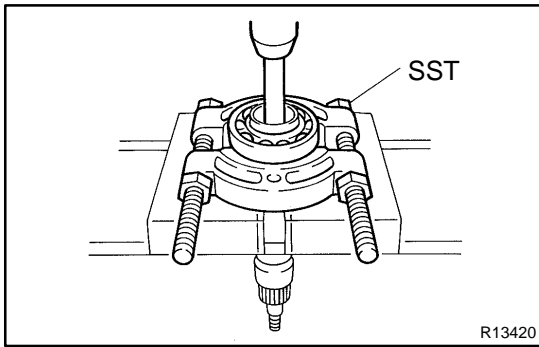

- (2) Using SST, a brass bar and press, remove the bearing.

SST 09950-00020

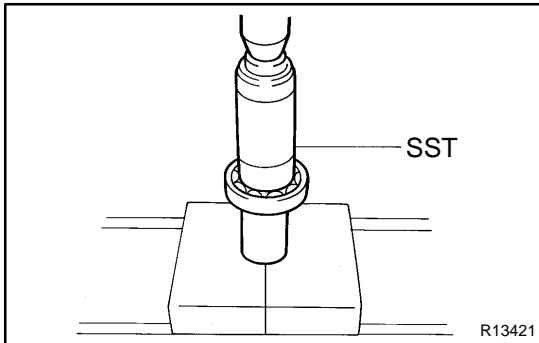

- (e) Install a new intermediate shaft No. 2 bearing.

(1) Using SST and a press, install a new bearing.

SST 09309-37010

(2) Using a snap ring expander, install a new snap ring.

- (f) Install the intermediate shaft No. 2 to the tube.

(1) Install the shaft into the tube.

(2) Using needle nose pliers, install a new snap ring.

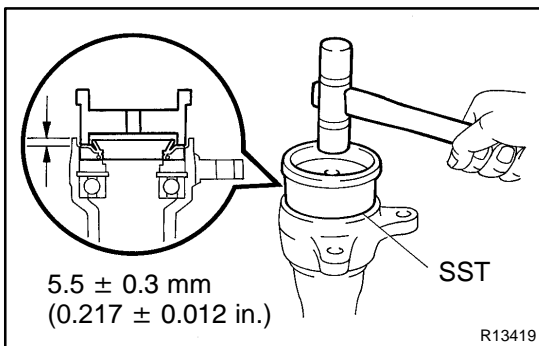

- (g) Install a new oil seal.

(1) Using SST and a plastic hammer, install a new oil seal.

SST 09223-15020

Oil seal drive in depth: 5.5 ± 0.3 mm (0.217 ± 0.012 in.)

(2) Coat the oil seal lip with MP grease.

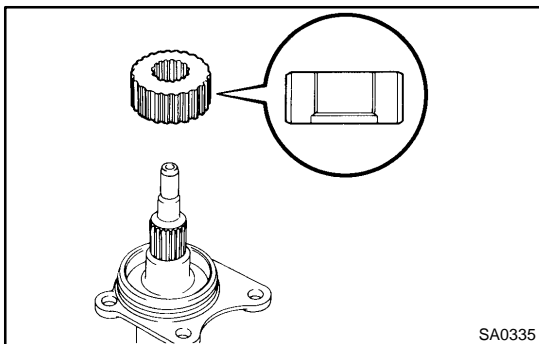

- (h) Install the clutch hub.

(1) Install the clutch hub to the shaft.

(2) Using a snap ring expander, install a new snap ring.